

MODEL

96K

## STAINLESS STEEL CENTRIFUGE PACKAGE

Specification Sheet

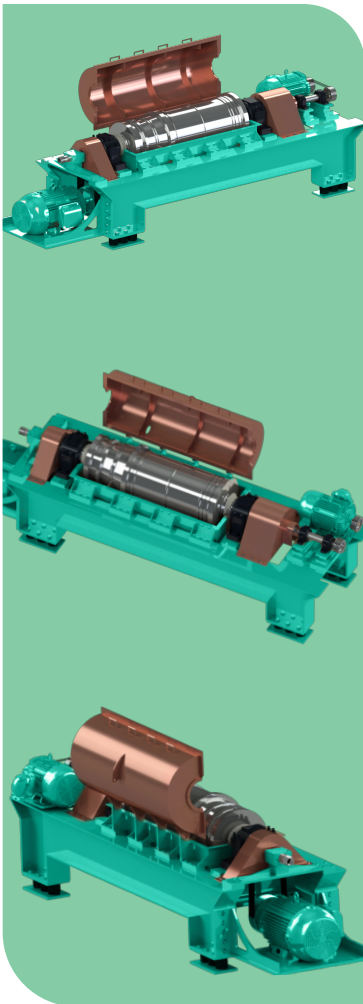

Centrifuge type:	Model 96K
Material of construction:	Stainless Steel
Bowl diameter:	24"
Bowl length:	72"
Conveyor type:	Axial or radial flow
Feed pipe:	3"
Conveyor wear protection:	Tungsten carbide tiles
Conveyor lead and pitch:	Double 9"
Gear unit Type:	K-100(planetary)100,000 IN/ LBS torque
Gear unit ratio:	76-1
Torque out style:	J8 coupling
Bowl sheave diameter:	14"
Pool depth setting:	0" - 4"
Main drive motor:	150 HP
Back drive motor:	40 HP
Maximum Speed:	3,000 RPM
Maximum G-Force:	3067
Gallons per minute:	500 GPM (Drilling Mud Application)

GreySun Equipment Company

3102 Ave M Extended Conroe, Texas 77301 (936) 524-5162 [centrifugeco.com](http://centrifugeco.com)

MODEL

96K



**GREYSUN**  
EQUIPMENT COMPANY

## STAINLESS STEEL CENTRIFUGE PACKAGE

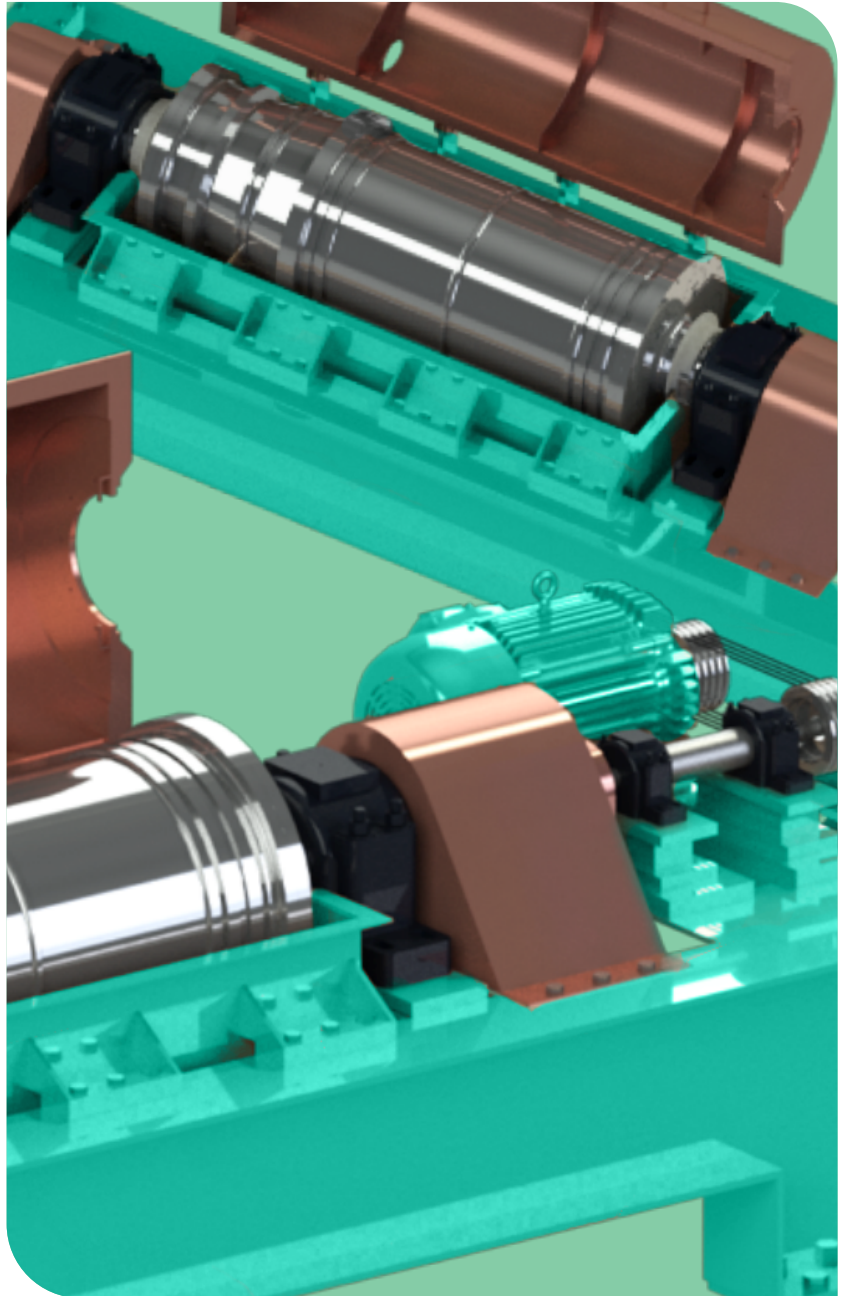

GreySun Equipment Company

3102 Ave M Extended Conroe, Texas 77301 (936) 524-5162 [centrifugeco.com](http://centrifugeco.com)